

SILVPAC[®] LM/BF-55

**WITH Bf-1 CONTROLLER, DIGITAL DISPLAY,
MICROPROCESSOR CONTROLS, AND
CAUSTIC DOSER TIMER**

(230 VAC, 50/60 Hz)

USER'S MANUAL

- **INSTALLATION**
- **OPERATION**
- **MAINTENANCE**

TABLE OF CONTENTS

RECOMMENDATIONS	3
IMPORTANT SAFEGUARDS	3
STATEMENT OF WARRANTY AND LIABILITY	4
GENERAL INFORMATION	5-6
The Desilvering Process	5
Drawing 1	5
Tailing "NR" Bleach-Fix	6
INSTALLATION AND SET-UP	7-8
Electrical Connections	8
CONTROL PANEL	9-13
Drawing 2	11
Programming the SilvPAC® LM/BF-55 Unit	11
Programming the Two Stage Plating	12
System Advance Key	13
OPERATION	14-16
Initial Start-Up	14
Automatic Operation	14
Table 1	15
Fail Safe Procedures	16
Master Reset	16
Chemical Recovery Conditions	16
Caustic Doser Timer	16
MAINTENANCE	17
Deplating (Stripping) Cathode (After six-ten Batches)	17
TROUBLESHOOTING	18-19
SPARE PARTS LIST	20
ELECTRICAL SCHEMATIC	
UNIT ASSEMBLY	21
DISCLAIMER	22

RECOMMENDATIONS

Read the entire instruction manual *before* installation or operation of the SilvPAC® LM/BF-55 silver recovery system. It will help you to understand the operation of the system, how various sub-assemblies work together, and the operating sequence of the controls.

WARNING: NEVER ATTEMPT TO PERFORM ANY ELECTRICAL TROUBLESHOOTING ADJUSTMENT(S) OR SERVICE(S) UNLESS YOU ARE A QUALIFIED ELECTRICIAN, ELECTRONICS TECHNICIAN OR FACTORY TRAINED SERVICE TECHNICIAN.

IMPORTANT SAFEGUARDS

When using the SilvPAC LM/BF-55 silver recovery system, these basic safety precautions should be followed:

1. Read and understand all instructions.
2. Care must be taken to avoid burns from touching hot parts.
4. Do not operate this appliance with a damaged cord or if appliance has been dropped or damaged until it has been examined by a qualified service technician.
4. Do not let power cord hang over edge of table or counter or touch hot surfaces.
5. An extension cord should not be used with this unit. The unit should be plugged directly into a power outlet.
6. To protect against electrical shock hazard, do not immerse this appliance in water or other liquids.
7. To avoid electrical shock hazard, do not disassemble this appliance. Call a qualified service technician when service or repair work is required. Incorrect re-assembly can cause electric shock hazard when the appliance is switched ON.

SAVE THESE INSTRUCTIONS

STATEMENT OF WARRANTY AND LIABILITY

All equipment manufactured by CPAC is guaranteed against defects in materials and workmanship for a period of six months, from the date of shipment from our factory. Any claimed defects must be reported, and the materials and/or equipment must be returned, freight prepaid, to our plant within the guarantee period. Our liability for defects in material and/or workmanship shall be limited to the replacing or repairing at our option, such defective materials and/or equipment at no cost to the purchaser. Any damages or loss occurring during shipment are not covered by this warranty, but are the responsibility of the carrier(s). Please report all shipping damage to the carrier(s) immediately.

All materials and/or equipment furnished by other suppliers carry no warranty except said supplier's warranty as to materials and workmanship. Transportation, handling damage, wear and tear, and other causes of damage outside the control of the manufacturer are not covered by this warranty. Under no circumstances will CPAC be responsible for any damage, loss or liability of any nature arising out of the installation and/or use of materials and/or equipment furnished.

There are no other warranties, expressed or implied, except as stated above. This warranty becomes null and void if any devices or accessories other than those distributed or officially recommended by CPAC, are installed or attached to, this equipment.

GENERAL INFORMATION

The Desilvering Process

SilvPAC® LM/BF-55 (electrolytic) unit may be used to desilver RA bleach-fix, plus low flow wash, C-41 fixer, E-6 fixer or combinations of these fixes and bleach-fix solutions. The recovery rate may vary with the type of chemistry desilvered, but good results can be achieved with all. The assay for silver recovered by the SilvPAC LM/BF-55 is normally greater than 96%. The SilvPAC LM/BF-55 unit has been designed for batch desilvering only. The unit includes a BF-I controller to automate the batch process. The necessary tanks, pumps, and plumbing is supplied as an optional tank package or provided by the customer. The operation is explained in Drawing 1.

Drawing 1

Standard SilvPAC-BF System for Non-Regenerating Bleach-fix

Step One – Collection: Overflow silver laden solution(s) is collected at the processor and transferred to the collection tank, T-1. This may be done using a CPAC ATS-5 Transfer Station (sump pump) or equivalent.

Step Two – Desilvering: When sufficient silver laden solution(s) have been collected, in tank T-1, the unit automatically transfers solution into the desilvering tank via pump P-1. After tank T-2 is full, the silver laden solution is pumped (P-2) into the cell tank where the silver is removed. The cell tank is elevated above the desilvering tank to allow all the bleach-fix to gravity drain from the cell tank after the desilvering process has been completed.

Step three- Transfer: After the desilvering cycle has been completed, the desilvered solution is transferred from the desilvering tank via pump P-3 to a tailing feed tank or post collection tank.

Tailing “NR” Bleach-Fix

NR bleach-fix (with or without the low flow wash) that has been desilvered electrolytically should be transferred to a “tailing” feed tank. The tailing system will remove the last traces of silver.

The drawings show two typical tailing systems used to completely desilver NR bleach-fix and/or fix.

A. Metering Pump System - Desilvered Solution from SilvPAC LM/BF-55 flows into the Tailing Collection Tank

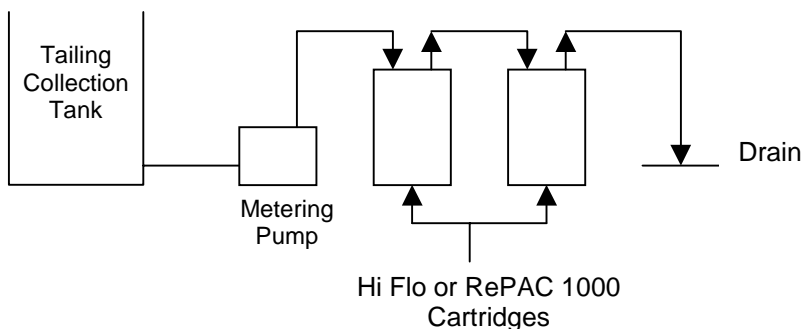

B. Gravity Flow System - Desilvered Solution from SilvPAC LM/BF-55 flows into the Tailing Collection Tank

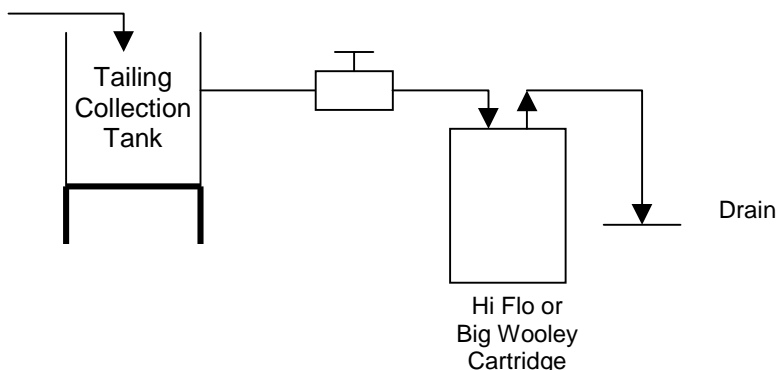

INSTALLATION AND SET-UP

Refer to Drawing 1 to identify plumbing components and pages 7 and 8 for electrical connections.

1. Install the desilvering tank (T-2). Install pumps P-2 and pump P-3. Install liquid level switches LL-2 and LL-3.
2. The SilvPAC LM/BF 55 must be installed above the desilvering tank (T-2) on either a platform or on the desilvering tank. This allows the unit to drain at the end of each batch. Two overflow hoses are located in the inner cylinder of the cell tank. These lines must return to tank T-2. Cut out the tank cover or platform to allow these lines to go straight down into tank T-2. Use flexible hose to extend these lines three inches below the solution level in tank T-2. If mounting the LM/BF 55 on a CPAC supplied desilvering tank, be sure that the steel frame extends over the front lip of the tank and the rear of the frame (where the pumps are mounted) extends over both sides of the tank. This will ensure that the unit is adequately supported. Connect the electrical cords from P-2, P-3, LL-2 and LL_3 as directed on pages 7 & 8.
3. Place the collection tank (T-1) in the desired location. Install pump P-1 with the necessary plumbing and liquid level switch LL-1. Connect the power cord for pump P-1. Connect the liquid level switch LL-1. (Refer to 7&8 for electrical connections). Connect the overflow from tank T-1 to drain.
4. If a post treatment tank is used, install the necessary pumps and liquid level switches.
5. Connect the "Drain" bulkhead (on the back of the LM/BF 55) to tank T-2. This is a return line from the cell tank to the desilvering tank; it should extend approximately 3 inches below the solution level in tank T-2. Start with the valve in the full open position. Adjust as needed to keep the cell tank full during desilvering.
6. Connect the outlet of pump P-2 to the bulkhead on the back of the LM/BF 55 unit labeled "Recirc Inlet". Connect the overflow fitting on tank T-2 to drain.
7. Connect the electrical power to the LM/BF 55 unit.
8. After installing the unit, water test the system to check for leaks or loose fittings. Using the CYCLE ADVANCE SWITCH, the water should pump from the collection tank to the desilvering tank (fill cycle) and to the LM/BF 55 cell tank (Desilvering cycle), and to the post treatment tank (Pump Out Cycle).

THE BULKHEAD ON THE BACK OF THE UNIT LABELED "CLEAN OUT DRAIN" IS A CONNECTION TO THE VERY BOTTOM OF THE CELL TANK. THIS IS INTENDED TO BE USED FOR PERIODIC CLEANING. DURING NORMAL OPERATION, IT MUST BE CLOSED.

PLEASE NOTE: Do not operate the pumps dry

Electrical Connections

The SilvPAC® LM/BF-55 should be connected to a 220 - 240 VAC, 20 Amp, power source. A standard power cord (#10, 3-wire) with strain relief connector or rigid conduit may be used. The complete schematic is included on page 24.

Connections for LM/BF 55

INCOMING POWER

L1 Incoming 220 VAC (HOT)
L2 Incoming 220 VAC (COM)
Chassis Earth GND

TERMINAL BLOCK TB-1

1	Cell Pump (P-4)(HOT)	The P-4 pump is wired at the factory.
2	Cell Pump (P-4)(COM)	
3	Cell Pump (P-4)(Earth)	
4	Recirc. Pump (P-2)(HOT)	The P-2 pump is wired during the installation.
5	Recirc. Pump (P-2)(COM)	
6	Recirc. Pump (P-2)(Earth)	
7	Fill Pump (P-1)(HOT)	The P-1 pump is wired during the installation.
8	Fill Pump (P-1)(COM)	
9	Fill Pump (P-1)(Earth)	
10	Pump Out Pump (P3)(HOT)	The P-3 pump is wired during installation.
11	Pump Out Pump (P3)(COM)	
12	Pump Out Pump (P3)(Earth)	
<i>The use of a caustic pump is optional</i>		
13	Caustic Pump (HOT)	
14	Caustic pump (COM)	
15	Caustic pump (Earth)	

LEVEL SWITCHES – Low Voltage - All level switches are wired at the factory.

16	Collection tank T-1 (LL-1)(Top)	Normally open*
17	Collection tank T-1 (LL-1)(Top)	
18	Desilver tank T-2 (LL-2)(Top)	Normally closed*
19	Desilver tank T-2 (LL-2)(Top)	
20	Desilver tank T-2 (LL-3)(Bottom)	Normally open*
21	Desilver tank T-2 (LL-3)(Bottom)	

*The normal position for level switches is the position that the switch will be in when the tank is empty.

All pumps must be rated for 230 VAC operation. Current draws must be between .1 and 3.0 Amps AC.

CONTROLS

LEFT PANEL OF SRU

Control

Main power disconnect
(Lock out/tag out)

Function

Rotary switch (red handle) that controls the power to the entire system

Operation

Turn main disconnect switch to OFF-"0" when servicing unit. Turn main disconnect switch to ON-"1" when operating unit

FRONT PANEL OF SRU (refer to drawing 2)

Control

System power ON/OFF

Ammeter hours/minutes operating information

Function

Controls electrical power to the entire unit

This display shows the remaining plating time when in DESILVERING cycle. This display is also used for operating information, troubleshooting and setting cell current and desilvering time

Operation

Must be ON for unit to operate

Displays time when in DESILVERING cycle. Displays cell current when settings are entered. Also displays error messages

KEYPAD

Control

System Cycle Advance

Function

Each push on the key will advance the system one step of the cycle. For example: from STANDBY to FILL, to DESILVER, to PUMP OUT, to STANDBY

Batch

Will display the number of batches processed

Time

Will display the amount of time in the DESILVERING cycle

Set

Pushing this key lights the indicator lamp in the upper right hand corner, allowing the operator to permanently change the time and/or amperage settings

Amperage

Will display plating amperage

Increase/Decrease

These keys are used to set the values of various system functions

Hold Pump Out

This key holds the P-3 pump from activating

STATUS LAMPS (indicate which cycle is active)

<i>Control</i>	<i>Function</i>	<i>Operation</i>
Standby	This unit is idle. It will start a batch as soon as the accumulation fills and fixer is transferred into the desilvering tank	Green LED is lit in STANDBY mode only
Filling	Pump P-1 is activated filling the desilvering tank (T-2)	Green LED is lit in FILL mode only, display shows FILL
Desilvering	Chemicals are being desilvered. The cell pumps and cell current are ON	Green LED is lit in the DESILVERING mode when solution is being desilvered
Hold pump out	Pump P-3 is deactivated preventing the desilvered solution from pumping out	Green LED is lit in the HOLD PUMP OUT mode
Pump Out	The desilvered chemicals are being pumped out through the discharge pump (P-3)	Green LED is lit in the PUMP OUT mode when the discharge pump is ON

CIRCUIT BREAKERS (Located inside the Control Box, Upper Left)

<i>Control</i>	<i>Function</i>	<i>Operation</i>
Main Breaker	Protects unit from power surges	Place in the ON position for normal operation
Cell circuit breaker	This protects the cell current power supply	Place in the ON position for normal operation
Cell pump circuit breaker	This protects the cell pumps and PCB	Place in the ON position for normal operation

CAUSTIC TIMER

<i>Control</i>	<i>Function</i>	<i>Operation</i>
Caustic (set/Lock)**	This allows the caustic doser timer to be changed	Place switch in SET position to change caustic doser time from 1 to 30 minutes

PROGRAM SET/LOCK SWITCH

<i>Control</i>	<i>Function</i>	<i>Operation</i>
Caustic (set/lock)**	This allows the desilvering parameters to be permanently changed	Place switch in SET position to change parameters

** Switches are located on the printed circuit board

CONTROL PANEL

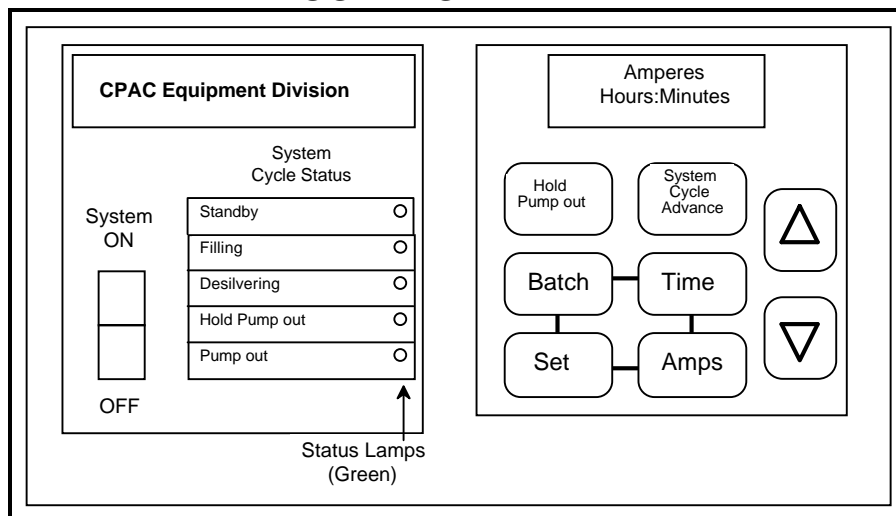

Drawing 2

Programming the SilvPAC[®] LM/BF-55 Unit

1. The unit is factory programmed for 115ps and 4hours. Both of these parameters can be changed.
2. There is a manual SET/LOCK switch on the component side of the Printed Circuit Board (PCB) This switch must be in SET position to make permanent changes to the plating time and amperage. When this switch is in the LOCK position, changes to plating time and amperage can be made but will be temporary and will be reflected only in the batch that is currently being desilvered. When the unit completes this batch, the plating time and amperage will return to the previous settings.
3. While in the desilvering cycle, the time remaining in the batch is displayed. If you wish to temporarily change the time remaining in the batch, press and hold down the TIME key. Either the hours or minutes will be displayed. If the HOURS is displayed and MINUTES is desired, release the TIME key and then press it again. Minutes will now be displayed. Adjust using the INCREASE or DECREASE keys. To temporarily change the amperage setting, press and hold down the AMPERAGE key and adjust up or down using the INCREASE or DECREASE keys. When the desired amperage is reached, release the AMPERAGE key.
4. To permanently reprogram the unit, the operator must enter the SET mode. *NOTE: Any or all of the following can be changed at any time in any order.*
SET: Press this key to enter the programming mode. Either the plating time or amperage will be displayed. A light in the upper right corner of the SET key glows indicating that the microprocessor is in the SET mode and values can now be changed.

TIME: Pressing this key will cause the existing hour digit to flash indicating this parameter can now be changed. Change the value by pressing either the INCREASE or DECREASE keys. When the new hours have been programmed, press the TIME key again and the existing minutes will begin to flash. Again change this value by pressing the INCREASE or DECREASE keys.

AMPERAGE: Pushing this key will cause the present amperage setting to flash on the display, which indicates that it can be changed. Change this setting with the INCREASE or DECREASE keys.

BATCH: Pressing the BATCH key will display the number of batches processed. To reset this counter, press the BATCH key and then press the DECREASE key -- this will reset the counter to 0. To display the permanent batch counter, press the BATCH key for four seconds. (this counter cannot be reset)

5. When using the INCREASE or DECREASE keys, each time the arrow is pressed the value will change by one. Holding down an arrow will change the value rapidly after an initial delay of about one second. Use this rapid change to get near the aim value and then use individual pushes until the exact value is reached.
6. When all programming is complete, press the SET key. The light in the upper right corner of the key will go out and the new values are entered into the microprocessor. Note that it is not mandatory to make all the above changes before pressing this key. New parameters can be entered into the system at any time by pressing the SET key.

Programming the Two Stage Plating

“Fine tuning” of the time and amperage can be obtained by reprogramming the percentage of elapsed time before the unit switches to reduced amperage. When the unit leaves the factory, it is set so that when 10% of the time remains, the unit automatically reduces the amperage to 90% of its set value. For example: Using RA bleach-fix set for four hours and 115 Amps, the unit decreases its amperage to 90% or 103 Amps when 24 minutes remain in the desilvering cycle.

To change the time percentage, press and hold both the SET key and the TIME key together and release both keys when the existing set time percentage begins to flash. Press the INCREASE or DECREASE key to change this percentage. Press the SET key to enter the new time percentage into the microprocessor.

Use the same procedure to change the amperage percentage except press and hold down both the SET and AMPERAGE keys. When desilvering bleach-fix solution, it is not recommended to decrease the amperage by more than 15%.

This “fine tuning” may not be needed by all labs when operating the SilvPAC unit. As a lab becomes more proficient with the operation, this procedure may be implemented.

System Cycle Advance Key

This key should be used by a qualified technician only. Problems, such as shortened cycles, pump head running dry damage, over/under desilvering times, etc. can occur if this key is pressed without knowledge of its primary function, which is to aid in servicing.

When the SYSTEM CYCLE ADVANCE key is pressed the unit will go into the next mode. For example, if the unit is in the DESILVERING mode and the SYSTEM CYCLE ADVANCE key is pressed, the unit will go directly into the PUMP OUT mode regardless of where it is in the desilvering cycle. The discharge pump will come ON and drain the desilvering tank.

If the unit is in STANDBY and this key is pressed, it will cause the transfer pump (P1) to switch on and fill the desilvering tank. Damage to this pump could occur if there is not enough liquid to adequately fill the desilvering tank - causing the pump to run dry. The LM/BF-55 unit is available with an optional tank and pumping package to simplify installation. To install the tank and pumping package, refer to Drawing 1 and follow the color coding on the fittings, pumps, and hoses.

OPERATION

Initial Start-Up

When the SilvPAC[®] LM/BF-55 is initially started up, the following preliminary steps must be followed since both the collection and desilvering tanks are completely empty.

1. Turn the system ON/OFF switch (on the front panel) to the OFF position. (Refer to Drawing 2)
2. Collect the silver laden solution(s) from the processor(s) in tank T-1 until solution starts overflowing from the safety overflow at the top of the tank.
3. Set the desilvering timer for the proper time as shown in Table 1.
4. Turn the system ON/OFF switch to the ON position. The System cycle status LED should switch from STANDBY to FILLING.

Automatic Operation

The SilvPAC LM/BF-55 is completely automatic. The entire desilvering process is controlled by liquid level switches and the microprocessor in the unit. The operation is explained below. Please refer to Drawing 1.

1. For typical operation, silver laden solution is collected in the collection tank T-1. During this period, the unit is in a STANDBY mode.
2. When sufficient solution has been collected, the liquid level switch LL-1 is tripped and pump P-1 transfers solution from the collection tank T-1 to the desilvering tank T-2. The FILLING status LED will illuminate.
3. As the solution is transferred, liquid level switch LL-3, in the bottom of the desilvering tank, will activate as the desilvering tank fills.
4. When the desilvering tank is full, the solution trips liquid level switch LL-2 near the top of the desilvering tank, pump P-1 is turned OFF and pump P-2 is turned ON. **The cell current and recirculation pumps are delayed for four minutes to allow the cell tank to fill.** The DESILVERING LED is illuminated and the AMPERAGE/HOURS: MINUTES display functions. *NOTE: While cell current is being delayed – FILL is displayed.*
5. The flow rate of the solution into the cell tanks should be adjusted to 4 gallons per minute (15L/m) using the flow meter provided.
6. The cell tank drain valve, located at the rear of the cell tank, should be fully open (this valve is connected to the bulkhead labeled “drain”). This will allow solution to drain out of the cell tank at the completion of the desilvering cycle. Adjust this valve as needed to keep the cell tank full during desilvering. The cell tank should drain in five minutes or less. Once the drain valve is set, it should be left in that position.
7. The bleach-fix will circulate between the desilvering tank T-2 and the cell tank for predetermined time as set on desilvering timer display. Set the current as indicated in table 1 below.

TABLE 1
Recommended Current Settings and Desilvering Times
(Based on 400 Liter (100 gallon) Batch)

<u>Type of Solution</u>	<u>Iron Concentration</u>	<u>Current Setting</u>	<u>Starting Silver Concentration</u>	<u>Time</u>
Bleach-fix & C-41 Fix (70%:30%)	4.5 gm/L	120 Amps	3.0 grams/liter	7 hours
NR Bleach-fix, LFW& C-41 Fixer	2.5 gm/L	70 Amps	2.5 grams/liter	7 hours
C-41 Fix Only	0 gm/L	40 Amps	5 - 6 grams/liter	15 hours

PLEASE NOTE: The current setting and desilvering times are only approximate and may have to be determined by the user to get efficient recovery and good quality silver. The current setting should be varied by 5-10 Amps from these given settings. A final silver concentration of 0.1 gm/L can be obtained for NR bleach-fix, C-41 fixer or combination of these solutions. The silver plate should be hard and light to dark brown in color. In some cases, the silver plate may be light gray in color.

8. After the desilvering time has counted down to zero, (and the HOLD PUMP OUT light is not ON) pump P-3 will automatically transfer solution out of the desilvering tank - Pump P-3 will remain on until the desilvering tank T-2 is empty and liquid level switch LL-3 trips. The green LED for PUMP OUT will illuminate.
9. When all of the desilvered solution has been pumped out of the SilvPAC LM/BF-55 desilvering tank, the desilvering time will automatically reset and the batch counter will record a completed batch. The SilvPAC LM/BF-55 unit is now ready to desilver another batch as soon as the collection tank is full and liquid level switch LL-1 is tripped.

NOTE: In the AUTOMATIC mode, protective circuits are provided to prevent pump P-1 from starting until the desilvering tank T-2 is empty.

NOTE: The SilvPAC unit incorporates a microprocessor to restart the unit for the remaining time when power is interrupted. This prevents the solution from being over or under desilvered. If the pump circuit breaker blows, the unit will stop. If the cell circuit breaker blows, the cell current will shut OFF.

Manual Operation

Manual operation of the SilvPAC LM/BF 55 system is not recommended except for testing, tank draining, or overriding the automatic control circuits in the event of a component failure. The SYSTEM CYCLE ADVANCE switch is used to manually operate the unit. **WARNING: There is no level switch control in the MANUAL mode. Strict operator attention is required.**

Fail Safe Procedures

The microprocessor continually checks for mechanical and electrical problems. Any problem affecting the plating action will be detected. ERR1 will be displayed when the unit cannot maintain the programmed cell current. This could be caused by an obstruction in pump P-2, the desilvering tank not being full, too low silver content in the chemistry or bad electrical connections. The message will continue to display until the problem is corrected. The time countdown does continue while ERR1 is being displayed.

Master Reset

If there appears to be a problem with the circuit boards, it is recommended that the boards be reset.

The circuit boards can be reset to their factory default specifications as follows:

1. Turn OFF the ON/OFF switch
2. Wait 30 seconds
3. Hold down the SYSTEM CYCLE ADVANCE key
4. Turn ON the ON/OFF switch

Chemical Recovery Conditions

The recommended RA bleach-fix solution characteristics for efficient silver recovery using a SilvPAC LM/BF-55 are:

pH :	7.0 to 8.2*
Iron Concentration:	2 ½ to 4 ½ gm/L
Silver Concentration:	2 to 3 ½ gm /L
Sodium Bisulfate Concentration:	4 gm/L (or greater) for NR Bleach-fix

**Most RA bleach-fix overflow from the processors will require a pH adjustment. Please consult with the manufacturer of the specific RA bleach-fix being used.*

Caustic Doser Timer

The caustic doser timer is built into the BF-I controller and automatically activates the caustic doser pump during the FILL cycle. This pump run time is adjustable from 1 to 30 minutes. To set this time, locate the CAUSTIC switch (black) on the PCB inside the unit. Set the switch to the SET position. The display will read C13, Caustic 13 minutes. Use the increase or decrease keys to change this setting. Once the desired setting is obtained, place the caustic doser switch into the LOCK position. The factory default setting is C15 (15 minutes).

MAINTENANCE

The following is a suggested maintenance schedule for your SilvPAC LM/BF-55 unit. Necessary instructions are given under each heading.

CAUTION: Before servicing the SilvPAC, turn both the system ON/OFF and main disconnect switch to the OFF position. ALWAYS use a mechanical device to lock out the disconnect switch before servicing.

Deplating (Stripping) Cathode (After Six - Ten Batches)

1. "Deplating" the cathode:
 - a) Remove the plastic cover from the cell tank.
 - b) Disconnect the cathode from the two connecting wires.
 - c) Lift the cathode straight up and remove from the cell tank.

The easiest way to remove the silver is by placing the whole cathode assembly in hot water for a few minutes and then into cold water. This will help break the bond between the silver plate and the cathode. Next tap the cathode with a hard rubber hammer on the seam to allow the cathode to break apart into two halves. Remove the silver from the two halves by tapping on the back of the cathode with the silver side down.

NOTE: Do not dent the cathode!

After the silver has been removed, the cathode should be cleaned with scouring powder and water before placing it back into the unit. Join the two cathode sections together and install the cathode in the cell tank. Place the anode assembly inside the desilvering cell. Connect the two wires to the cathode. Replace the covers on the cell tank. Place the system ON/OFF and main disconnect switches in the ON position.

Every Six Months

1. Cathode - Check for dents and roundness. Replace as needed.
2. Pumps - Check pumps and repair or replace if necessary.
3. Anode Basket - Check for eroded anodes and replace as needed.
4. Anode and cathode connections. Check all connections to the anode and cathode for corrosion. Tighten or remake connections as necessary.
5. Bottom of cell tank. Silver fins or knobs may fall off the cathode and become trapped in the cell tank. This silver should be removed to prevent any excessive wear to the cell tank.
6. Liquid level switches. Inspect the liquid level switches making sure that they move freely and are functioning properly. Remove any dried bleach-fix that would interfere with the operation of the liquid level switches.
7. Cathode coating. Check the cathode coating for exposed areas where the metal can be seen. If it becomes badly chipped or loose the cathode coating may need to be replaced. Please contact CPAC, Inc. or its distributors for details about replacement parts.

TROUBLESHOOTING GUIDE

A. Chemical	Possible Cause	Corrective Action
Limited current	Low solution conductivity	Check iron and silver concentration and refer to Table 1
Low plating rate	Low sulfite concentration	Check sulfite concentration. If lower than 4gm/L, add 4 gm/L
Silver sulfide formation (Black ppt)	Desilvering time is too long	Shorten time, desilver down to between .1gm/L and .5gm/L of silver
Silver sulfide formation (Black ppt)	Low sulfite concentration	Check sulfite concentration. If lower than 4gm/L, add 4 gm/L. If silver is low, end the batch and clean the cathode
Black silver plate	Current setting too high	Refer to the current setting in Table 1 after checking the iron concentration.

TROUBLESHOOTING GUIDE

B. Mechanical	Possible Cause	Corrective Action
Internal knocking sound in cell	Cathode out of place	Remove cathode and join it together at the two seams
Rec. Pump fails to start	Pump circuit breaker blown	Reset circuit breaker
Rec. Pump fails to start	Loose wire	Check and tighten wiring
Rec. Pump fails to start	Defective PCB	Replace main PCB
Rec. Pump fails to start	Burned out	Replace pump or pumphead

C. Electrical	Possible Cause	Corrective Action
Green LED in SYSTEM CYCLE STATUS does not illuminate	No power to unit	Check circuit breakers and system switch
Green LED in SYSTEM CYCLE STATUS does not illuminate	Main PCB	Reset main PCB by holding down the SYSTEM CYCLE ADVANCE key when turning ON the main power. If that is not successful, replace main PCB
Limited cell current or fluctuating cell current, limited or no plating	Loss of electrical connection	Disconnect power to unit. Check all connections including; transformer, diode, heat sink, panel terminals, shunt, anode rings and PCB. Tighten any loose connections & replace any corroded wires or terminal connections.
No plating	Operating current too low	Check operating current. Table 1
Limited current	Open diode	Check diodes and replace if necessary
Pumps do not work	Pump circuit breaker blown	Reset circuit breaker
Pumps do not work	PCB failure	Replace main PCB
Pump P-1 doesn't stop	LL-1 or LL-2 switch shorted	Check LL-1 & LL-2, replace if necessary
Pump P-1 doesn't start	LL-1 open	Fill collection tank, check LL-1 for continuity
Pump P-3 does not stop	LL-3 shorted	Check LL-3 and replace if necessary
Pump P-3 does not stop	Faulty main PCB	Replace main PCB
Limited cell current or fluctuating cell current	PCB failure	A 20 millivolt DC signal should be obtained across shunt J3(7), J3(8) on PCB at 30 Amps. Replace PCB (1 millivolt DC across shunt = 1.5 Amps through the cell)
Unable to adjust current below 40 Amps on display	Triac shorted	Replace Triac
No Cell current	Cell tank not full	Check cell tank liquid level
No Cell current	Cathode not connected	Check cathode connection
No Cell current	Open circuit	Check electrical connections, diodes and transformer.
No Cell current	Bad triac	Replace panel mount triac

SilvPAC LM/BF 55

Spare parts list

CPAC PART NO.	DESCRIPTION	CATEGORY	QUANTITY USED
	Anode Cable	Elec	1
	Cathode Cable	Elec	2
702751	Choke CH-200	Elec	1
700235	Choke CL-12-24	Elec	1
702874	Circuit Breaker, 10A, DIN Rail	Elec	1
702754	Circuit Breaker, 20A, DIN Rail	Elec	1
700513	Diode, 150 Amp, 50 Volts	Elec	2
700797	Fan, 4", 230V	Elec	1
702655	Key Pad, SilvPAC-BF	Elec	1
SP-143P2011	Liquid Level Switch w/ nut and washer	Elec	3
702682	Power Switch	Elec	1
703033	Recirculation Pump, Iwaki, 230V	Elec	2
702752	Resistor, 2 Ohm 100 Watt	Elec	1
700474	Shunt 200A-50mV	Elec	1
602525C	SilvPAC BF control PCB	Elec	1
702750	Switch Handle, Disconnect, Red/Yellow	Elec	1
702749	Switch, Disconnect, 20A, 3 Pole	Elec	1
702699	Terminal Block UK-5	Elec	18
700824	Transformer DL-16-100, 115/230V	Elec	1
702684	Triac, 40A, 400V	Elec	1
703179	Anode 18" x 1 7/16" x 1/2"	Mech	22
602726	Anode Bracket	Mech	2
602724	Anode Ring	Mech	1
781004	Bolt, Anode, 1/4-20 x 1 1/4"	Mech	2
51-114P2115	Bolt, Anode, 1/4-20 x 1"	Mech	20
602757	Cathode Assembly	Mech	1
702957A	Cell Tank	Mech	1
701720	Flowmeter, 0.5-5.0 GPM	Mech	1
702946B	Lid, Dome	Mech	1
702951	Lid, Gasket	Mech	1
49-107P2033	Nut, 1/4-20	Mech	22
602735	Splash Guard w/ knob	Mech	1
783005	Washer, split, 1/4-20	Mech	22
701751	pH Test Paper	Misc	
700611	Silver Test Paper	Misc	
700612	Sulfite Test Paper	Misc	
602758	Spare Parts Kit, LM/BF-55	Kit	
	Cathode Assembly		1
	Diode, 150, 50V		2
	Triac, 40A, 400V		1
	Liquid Level Switch w/ nut and washer		2

EVERY EFFORT HAS BEEN MADE TO INSURE THE COMPLETE ACCURACY OF THE CONTENTS OF THIS MANUAL. NO LIABILITY ARISING FROM ITS USE, HOWEVER, CAN BE ACCEPTED BY THE COMPANY, WHO RESERVES THE RIGHT, WITHOUT PRIOR NOTICE, TO ALTER THE SPECIFICATIONS, CONSTRUCTION, OR CONTENT OF ITS EQUIPMENT AT THE COMPANY'S OWN DISCRETION.